



**A COLORFUL WORLD
OF POSSIBILITIES
WHERE STRUCTURES
PAVE A VIBRANT
FUTURE**



Scan to know more

Corporate Office

SG Centre, 37C, Block A, Sector 132, Noida, Uttar Pradesh 201304, India
T : +91 - 120 6918000 F : +91-120 4041444

Stay connected. Stay updated.

[f](#) [in](#) [x](#) [v](#) [@](#) / APLAPOLLO COATED STEEL OFFICIAL | TOLL FREE: 1800-102-3737

Website : www.aplapollocoatedsteel.com | email : coatedsteelmarketing@aplapollo.com

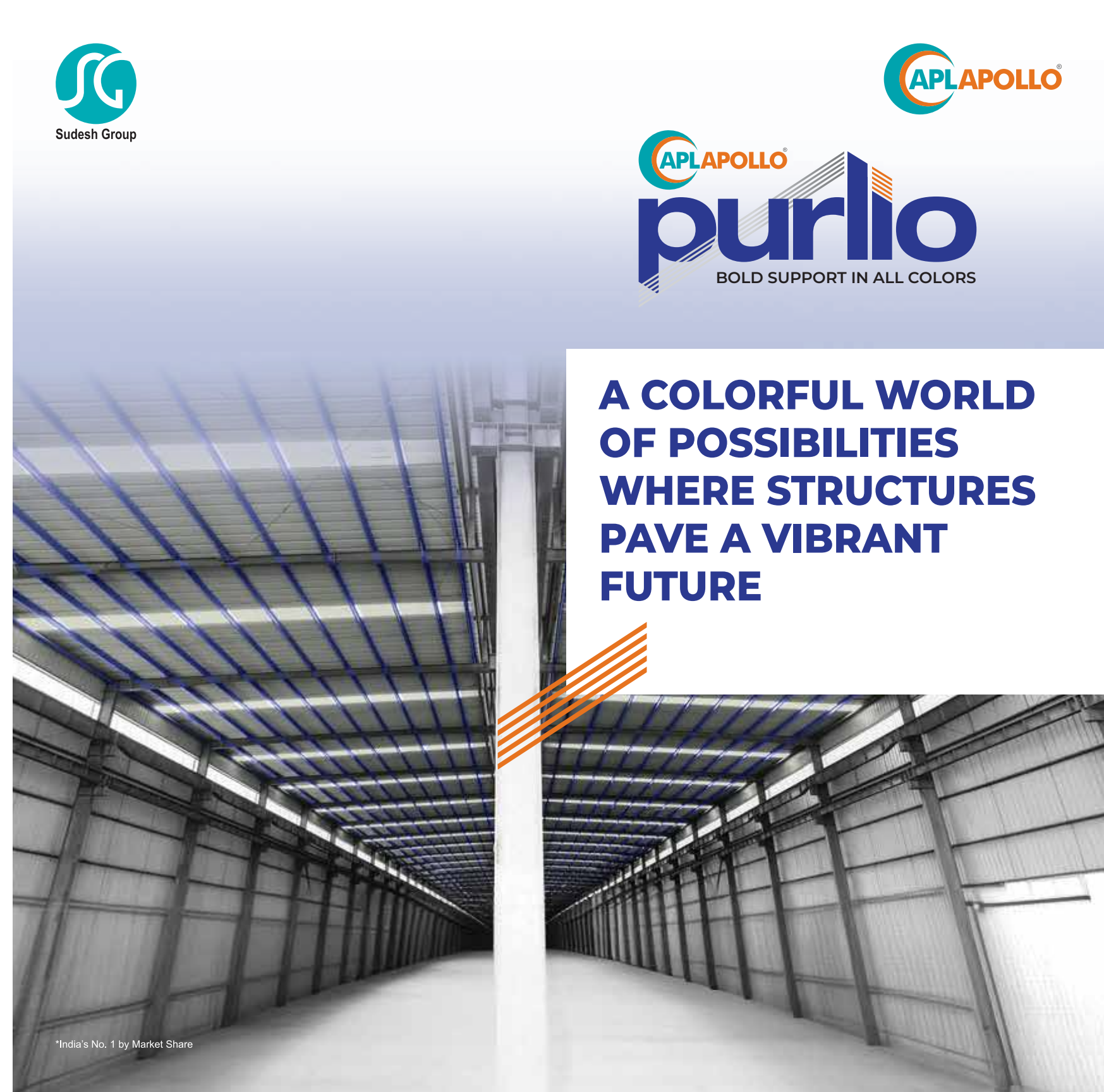

*India's No. 1 by Market Share

INDEX

About APL Apollo Group	02
Sustainability is at the core of APL APOLLO	04
Our Plant	06
Challange in galvanized steel	08
Is Zinc porous or water proof?	08
A Revolutionary Change Why PPGI & PPGL is better than galvanised product	09
APL Apollo Purlio	10
Why should purlio replace galvanized	12
It is the right time to convert various applications from GI to PPGI /PPGL	13
Purlio with multi layers of protection in colour coated	14
Zinc consumption on PPGI vs corrosion results	15
Visual Appeal Meets Budget	16
Z-Purlio	18
C-Purlin	19
Technincal Specification	20
Applications	22
Environment	24
Our Presence	25

1st Time In India

**COLOUR COATED
PURLINS —
THE SMARTER SOLUTION**



ABOUT APL APOLLO

APL Apollo Tubes Limited stands tall as the largest producer of Structural Steel Tubes in India.



Our Legacy of Excellence

APL Apollo, with over a decade of experience, has become a leader in structural steel tubes. Their focus on quality positions them as a major industry player.



Innovative Capacity Investment

We prioritize future success. Consistent investments in manufacturing capacity solidify our industry pioneer status. This strategic approach ensures efficient, precise fulfillment of regional demand.



Pioneering Technology Adoption

APL Apollo is driven by innovation. For two decades, they've been a leader in bringing cutting-edge tech to India, developing new products and markets.



Expansive Product Portfolio:

Our vast product portfolio (over 2,000 SKUs) reflects our commitment to innovation. We offer a variety of structural tubes, hollow sections, and more, catering to diverse needs.



Robust Distribution Network

Accessibility is key. Our industry-leading distribution network ensures products are readily available across India, thanks to robust supply chains.



Driving Trade Transformation

We set the bar, not meet it. Innovative products, fast delivery, and partner growth opportunities redefine industry trade practices.



A Commitment to Innovation

Innovation is our core. We develop solutions for evolving needs, delivering value. Our cutting-edge Raipur facility exemplifies this, producing innovative products for India.

3.6 MT
Steel products

30
Countries across the Globe

11
Manufacturing units

SUSTAINABILITY IS AT THE CORE OF APL APOLLO

Our environmental management is not a strategy but a philosophy embedded in the substrata of the enterprise, it allows us to reduce our carbon footprint and also inspires our customers meet their own environmental management aspiration.



Products:

We are the first and pioneering Company to innovate readymade Chaukhat, Fence, Plank, and Hand rails under Steel for Green concept which replaced conventional wood applications in building construction. Our product saves approximately 250,000 trees every year.



Energy:

Our total renewable energy stood at 49,618 MW, which is 38% of APL Apollo's total energy consumption. To achieve its near-term emissions reduction targets, APL Apollo plans to increase the use of renewable energy. At two of APL Apollo's plants (in Malur, Karnataka and Hosur, Tamil Nadu), over 85% of energy needs were met through renewable energy.



Green cover:

We have planted 5,000 plants on 3.1 acres of government-provided land in Gendupur Village, Sikandrabad, close to our AMPL (A25/Plot 22) and APL A19 manufacturing plants. Furthermore, we have undertaken a large number of plantation activities in our plants at APL Apollo Building Products Private Limited (ABPL). For the plantation of thick, natural mini-forests, we have adapted the Miyawaki technique pioneered by the Japanese botanist Akira Miyawaki. The method will result in ten times faster plant growth and a plantation that is 30 times denser than typical.



Water:

Over the years, we have persevered to optimise water consumption at our facilities by strengthening our shop-floor processes. Our patient efforts have yielded heartening results. Over the last three years (FY20-FY23), our total water consumption declined by 9% YoY despite a 30% jump in production. Our two facilities at Murbad and Malur are Zero-Liquid Discharge certified. To rejuvenate the groundwater table, we have created rainwater harvesting pits of around 353 cubic meters.

MEMBER OF
**Dow Jones
Sustainability Indices**
In Collaboration with RobecoSAM



DJSI FY2023 SCORE

APL APOLLO TUBES
STANDS AT 86TH
PERCENTILE

(IN THE PEER INDUSTRY COMPRISING OF GLOBAL COMPANIES)

**SCORE REACHED A HIGH OF
40 POINTS, ABOVE THE INDUSTRY AVERAGE OF 24**

IMPROVEMENT ACROSS AREAS



**Social
Dimension**



**Governance &
Economic Dimension**



**Environmental
Dimension**



OUR PLANT

The Raipur Facility: Driving Innovation and Sustainable Growth

Manufacturing Plant Overview:

APL Apollo's manufacturing facility located at Simga, Raipur spans across a vast 600-acre landscape, our facility stands as a testament to our commitment to excellence in the manufacturing of steel tubes and building products.

With a current annual capacity of 1 million tons and additional expansion capabilities of 0.3 million tons, our facility is equipped to meet the growing demands of various industries.

Our facility boasts a range of groundbreaking product innovations, including:



India's first 20mm HR Slitting Line



Launch of India's first 500 x 500mm Structure Tube Section and Introduction of 1000 x 1000mm Structure Tubes, a pioneering feat in India and globally.



Implementation of India's first Thicker Colour Coating Line, offering superior coating thickness ranging from 1.60mm to 2.50mm

Our operations prioritize environmental sustainability, with features such as:

- A Zero Discharge Plant, ensuring minimal environmental impact.
- Implementation of an Acid Regeneration Plant, promoting eco-friendly practices.





CHALLENGES IN GALVANIZED STEEL

- Red Rust & white Rust
- Flux Deposition
- Moisture content
- Entire dependence only on one layer and that is Zinc Coat
- If Zinc coating fails there is no more layer of protection at all
- The entire life of steel is based on Zinc coat only

This results in-



IS ZINC POROUS OR WATER PROOF ?

Zinc is not waterproof but it can be used to help protect other metals from high levels of corrosion when exposed to water. Rather than being used in its pure form, zinc is most often used to form metal casting alloys. This is because zinc corrodes at a slower rate than many other metals.

2 basic types of rust:



White Rust

Red Rust

A REVOLUTIONARY CHANGE - WHY PPGI & PPGL IS BETTER THAN GALVANISED PRODUCT

Case Study

Cutting Edge of Corrosion Resistance - Post painted galvanized vs. Pre painted

- Even with exposed cut edges, pre painted metal outperforms post-painted parts.
- Pre painted metal louvers with exposed cut edges were tested in the field against post-painted metal louvers, one with an electro coat, a second with a powder finish, and a third with a spray finish. The parts in all instances were made of hot dipped galvanized steel and louvers were exposed to the same environment over time in Daytona Beach, Florida.
- After 16 months, 44 months, and 68 months of exposure to the elements, comparisons showed the pre-painted parts were repeatedly and significantly more corrosion resistant than the post-painted parts.
- Experts agree the reason that the pre painted parts outperformed all three post-painted parts is that pre painted metal sheet is uniformly cleaned, treated and painted as a flat surface, so the edge to edge and side to side variability is virtually eliminated





APL APOLLO PURLIO

In the world of pre-engineered buildings, APL APOLLO PURLIO are changing the game for roof support. Crafted from cold-formed steel for superior strength, these innovative elements offer a clear advantage over traditional galvanized iron. They are both more affordable and environmentally friendly, boasting impressive flexibility (0T to 3T bend) that makes them ideal for bridging applications.

COLOUR OPTIONS

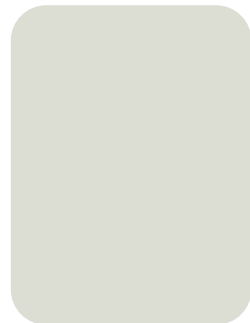

RAL 9002

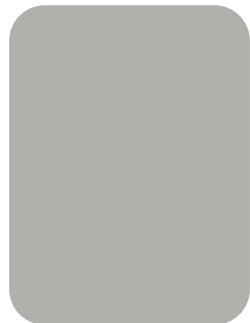

RAL 7038

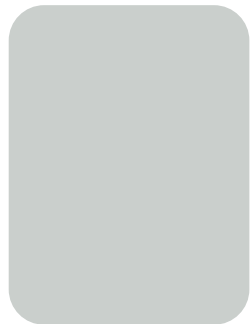

RAL 7035



RAL 5018



BRICK RED

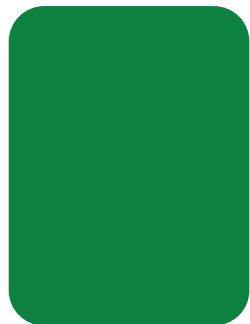

CAULFIELD GREEN

*More colour options available on requirement



KEY FEATURES

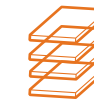

4 Coat Paint System



30 Micron Paint Coating



RMP Paint



Metallic Coating Z80/Z120/Z180/Z275



Coil Width up to 750mm



BIS Certified

QUALITY TESTS

QUV



750 HOURS Weathering Test

Humidity



750 HOURS

Boiling water



UP TO 2 HOURS Weathering Test

Salt Spray



750 HOURS Corrosion Test

Heat Resistant



UP TO 24 HOURS 100° C

MEK Solvent



TOP/BOTTOM COAT 100DR/50DR Colour and Blister Test

WHY SHOULD PURLIO REPLACE GALVANIZED ?

Basic Parameters required for PEB	Conventional Method of using Galvanised sheets	What does Purlio offer for PEB?	Benefits of using Purlio
Salt Spray	≤ 120 Hrs	Between 750 to 1000 Hrs	Much better weatherability, Corrosion resistance and Humidity resistance
Zinc Coating	275 GSM	120 GSM and 25 μ further paint coatings	100% Prevention from White Rust & Red Rust
Aesthetics	Only single colour	Eye catching with vast range of RAL shades	Innovative aesthetics
Durability	Short term shelf life	Almost 4x service life as compare to conventional	Products can be available with Long duration warranty periods
Processing time	In house paint processing	Ready made product available	No paint shop required at all and its much easier to work with.



PPGI WITH 120 GSM OR PPGL 150 AZ

Means minimum 750 HRS SALT SPRAY RESULTS + AESTHETICS + DURABILITY + CORROSION RESISTANCE & MANY MORE without any price impact.

IT IS THE RIGHT TIME TO CONVERT VARIOUS APPLICATIONS FROM GI TO PPGI /PPGL

- PEB Sector never thought of making colour coated Purlin because this option was never available earlier. The existing Lines were not capable enough to produce these sizes
- The maximum thickness available was 1.2 MM in galvanized & 1.6 MM in Galvalume
- Apollo is now giving this option with world class Facility from its Raipur plant in width from 300 to 750 MM and thickness from 0.3 to 2.5 MM
- The flexibility, high efficiency, and green benefits of coil coated metal are driving the demand for pre painted metal in many industries. Designs can be eye-appealing - simple or complex, without compromising long-term durability, corrosion and mar resistance properties, and functionality



PURLIO WITH MULTI LAYERS OF PROTECTION IN COLOUR COATED

- No flux depositions refer to absence of material buildup or layering which can result in premature local coating failure.
- Ensure surface cleanliness through degreasing and cleaning to achieve optimal conditions for subsequent procedures or applications.
- Apply a dual protective coating over zinc to enhance durability and corrosion resistance, ensuring superior longevity and performance in harsh environments.
- Apply a primer over the phosphate treatment (PT) for extra protection, improving adhesion and durability against corrosion and wear for better surface preparation.
- Apply a top coat over the primer for enhanced protection, improving appearance and durability against environmental factors like UV rays, moisture, and abrasion.
- Multiple Layers of protection ensures that rust can not occur during punching or any other bending acts

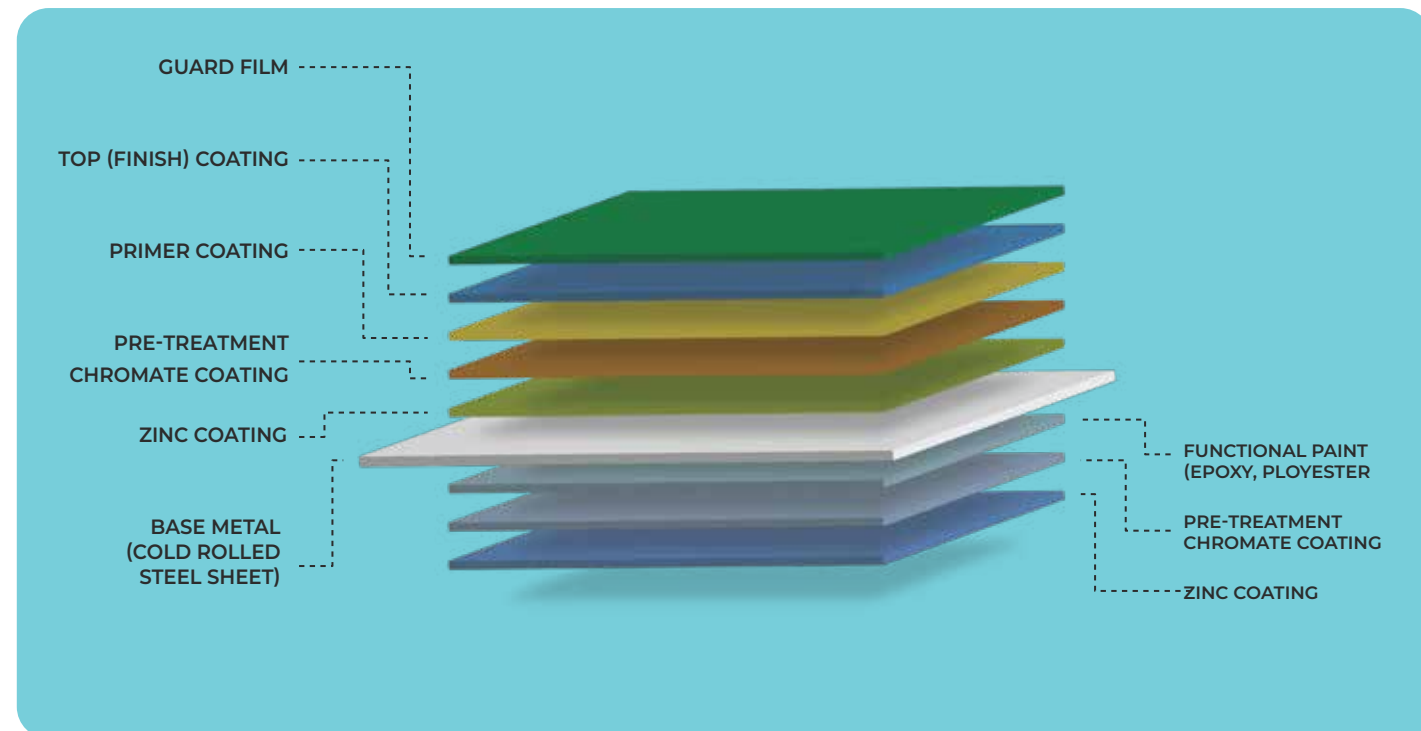

ZINC CONSUMPTION ON PPGI VS. CORROSION RESULTS

Zinc Consumption in colour Coated Vs. Salt Spray result

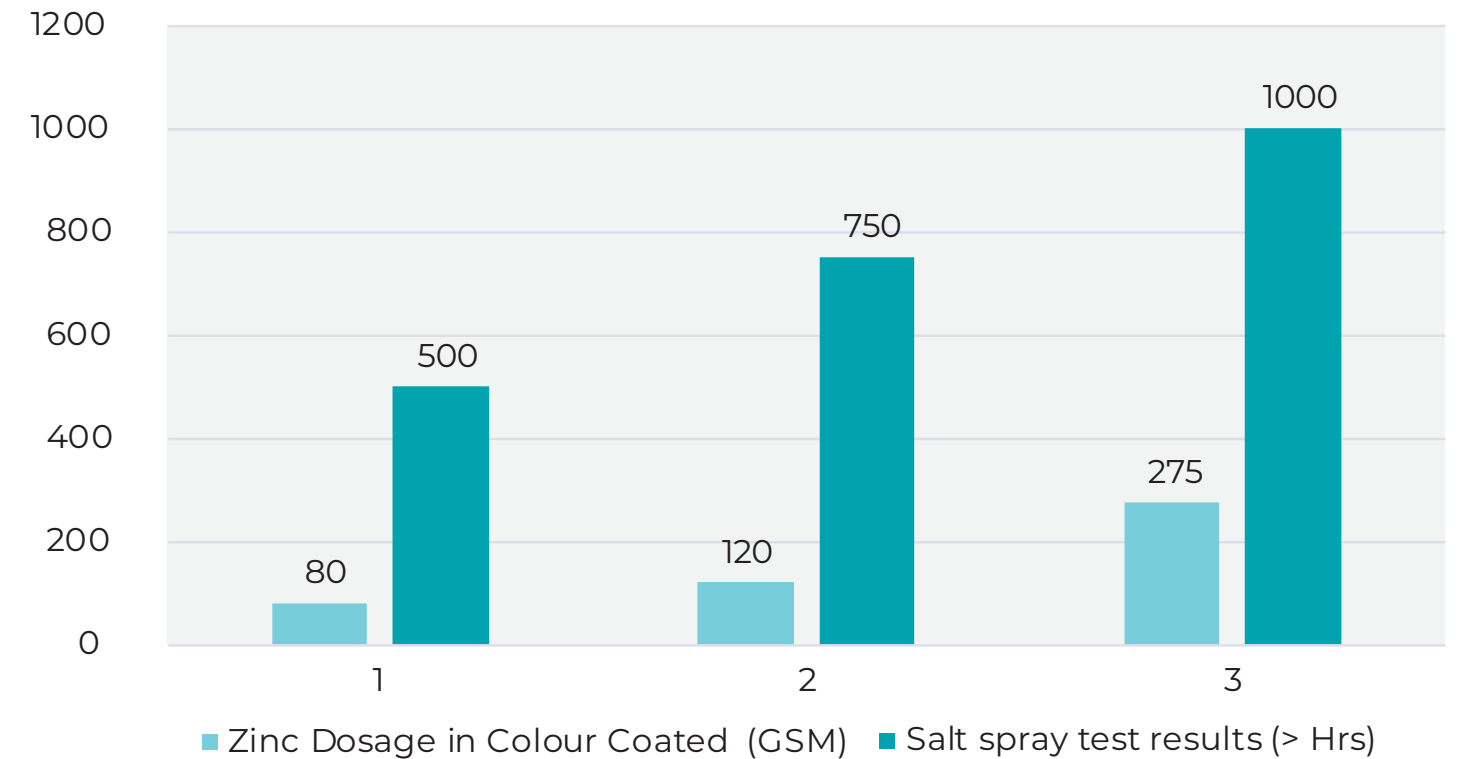

Do You Know ?

High thickness of zinc coating doesn't guarantee better corrosion resistance always ; rather the thicker layer sometimes solidify and get cracked-these cracks give warm welcome to rust.



VISUAL APPEAL MEETS BUDGET: Colored Purlins, the Smarter Solution

60m x 155m x 10m shed				Unit price with colour coated	Amount price with colour coated purlin	Cost difference
Area 100068 SQF						
Item	BOQ	Unit Price	Amount			
Super Steel Structure						
Main Structural Steel	177120 KG	100	1,77,12,036	100.00	1,77,12,036	
Cold form Z section (Purlin & Girts)	42203 KG	70	29,54,231	75.00	31,65,247	
Hot rolled (Cleats, Sag rod, cage ladder etc)	15941 KG	100	15,94,083	100.00	15,94,083	
Anchor bolts	5882 KG	100	5,88,161	100.00	5,88,161	
Bolts	8470 KG	120	10,16,343	100.00	8,46,952	
Plates	31952 KG	100	31,95,163	100.00	31,95,163	
TOTAL =	281567 KG		2,70,60,016		2,71,01,642	0.2%
Roof Sheet	9907 SQM	478.85	47,44,106	478.85	47,44,106	
Wall sheet	4583 SQM	478.85	21,94,570	478.85	21,94,570	
Gutter	341 M	612.928	2,09,008	612.928	2,09,008	
Downtake	1193 M	251.2	2,99,682	251.2	2,99,682	
			74,47,365		74,47,365	
Total cost difference			3,45,07,382		3,45,49,008	0.1%
Note:- Quantity Tolerance ±3-5%						



**Don't
settle
for ordinary.**

Invest 0.1% more for stunning aesthetics, unmatched durability, and a building that stands out.



Z PURLIN

These steel purlins are widely appreciated for their veracity and are extensively used in large sized roofing railway platforms, workshops, factory sheds, godowns and other industrial sheds. Z Purlins are stronger than C purlins and are most commonly used in joints and overlaps. These purlins are placed between the roofing sheet and structure and provide optimum support to the primary framing system. Z-purlins can be lapped, which is done by rotating one Z-purlin 180 degrees and having it fitted to another one.

RECOMMENDED HOLE, CLETS AND FASTENING DETAILS

Standard THI Z-sections are supplied with optional holes punched to order. Punched Z-section can be supplied with H14, H16, H18 or elongated holes, with recommended cleat size as stated in table below.

SECTION DEPTH (mm)	A (mm)	B (mm)	C (mm)	
100	50	35	110	6
125	50	45	120	6
150	80	45	150	6
200	110	55	190	6
250	150	60	235	8
300	200	60	285	10

DIMENSIONS & PROPERTIES

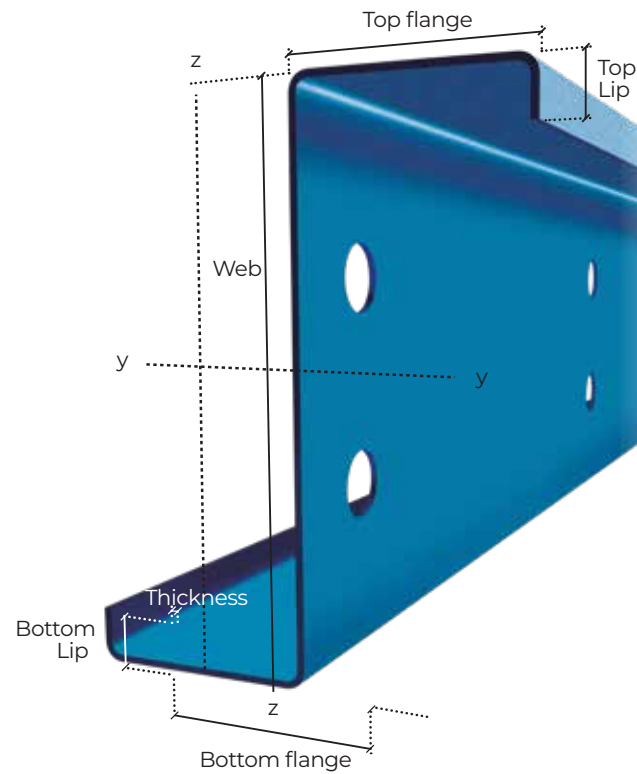
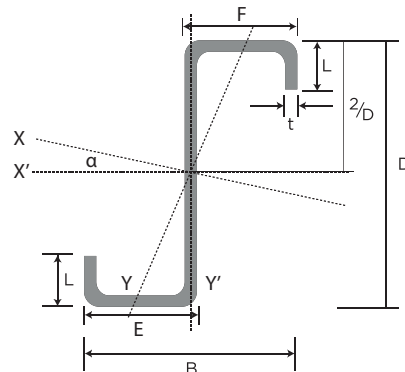

C PURLIN

As the name itself suggests, these purlins bear shape like alphabet C. They are commonly used to support walls and floors. C purlins are also sometimes referred to as channel section purlins when they have flange stiffeners and U-sections when they do not. C-sections are those which are monosymmetrical. These sections cannot be lapped, but the stable shape ensures easy packaging and transportation. The C-section purlins are widely used in clear span design due to their high stability factor.

RECOMMENDED HOLE, CLETS AND FASTENING DETAILS

Standard THI C-sections are supplied with optional holes punched to order. Punched Z-section can be supplied with H14, H16, H18 or elongated holes, with recommended cleat size as stated in table below.

SECTION DEPTH (mm)	A (mm)	B (mm)	C (mm)	
100	50	35	110	6
125	50	45	120	6
150	80	45	150	6
200	110	55	190	6
250	150	60	235	8
300	200	60	285	10

DIMENSIONS & PROPERTIES

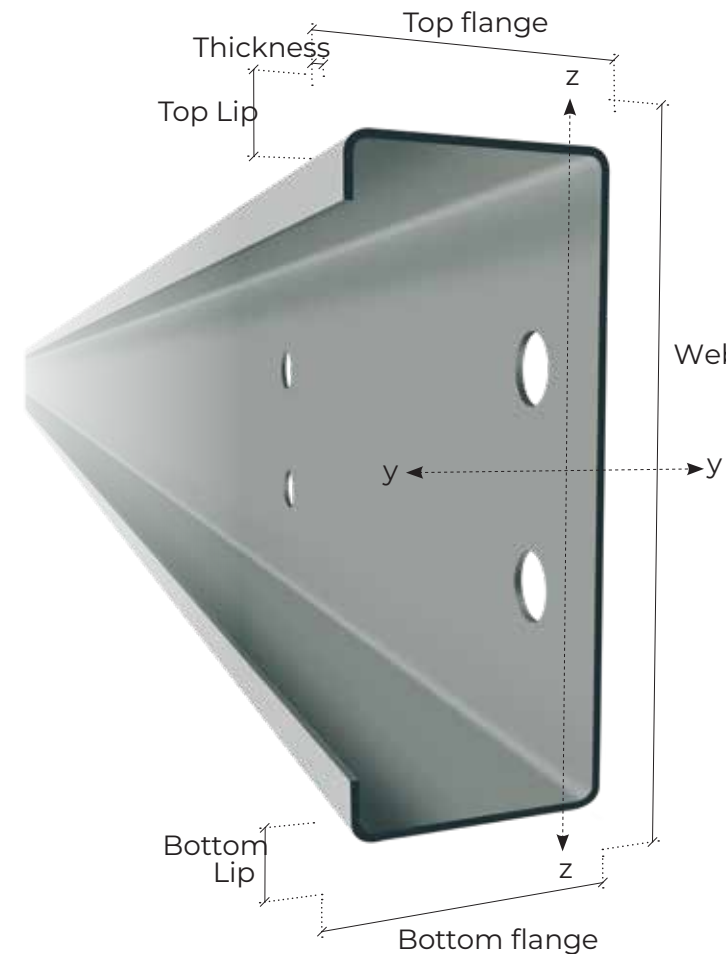
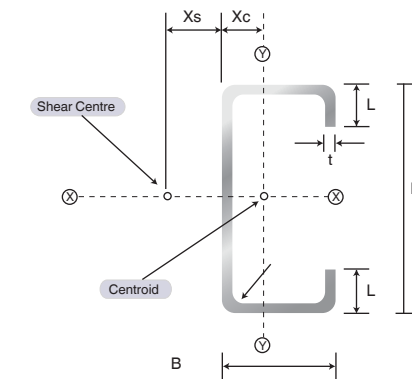



ENSURING CORROSION PROTECTION

A zinc coating of Z80/Z120/Z275 galvanised sheet combined with 36 micron paint is the standard coating class provided with APL APOLLO PURLIO Coils. This will provide a long and trouble free life for enclosed buildings and open sided rural buildings, in a non-aggressive environment. (A non aggressive environment is 1000m from rough surf, 750m from industrial emission and fossil fuel combustion and 300m for calm salt waters)

COMPATIBILITY WITH OTHER STEEL PRODUCTS

The coating on purlin is fully compatible with the zinc and aluminium/zinc coatings used on roof and wall sheeting. If minor damage occurs to the purlin coating, the base steel is protected by its own surrounding coating. Furthermore, the protective coating on the sheeting is not corroded by an un-protected base steel nearby.

TECHNICAL SPECIFICATIONS

NARROW DIVISION CCL SHADE DEVELOPMENT SOP _14.12.2023											
Product	Top Colour	Primer DFT(µm)	Finish DFT(µm)	Total Top Coat DFT(µm)	Back Colour	Primer DFT(µm)	Back Finish Coat (µm)	Total Back Top Coat DFT(µm)	Top Gloss@60° (GU)	Back Gloss@60° (GU)	Top Paint Type
PURLIN (top and bottom same colour)	RAL 9002	4-5	14-15	18-20	RAL 9002	4-5	14-15	18-20	35±5	35±5	RMP
	RAL 7038	4-5	14-15	18-20	RAL 7038	4-5	14-15	18-20	35±5	35±5	RMP
	RAL 7035	4-5	14-15	18-20	RAL 7035	4-5	14-15	18-20	35±5	35±5	RMP

1. Thickness range 1.5 MM to 2.5 MM.
2. Galvanize Coating 80 GSM to 275 GSM as per requirement.
3. Regular colors are Ral 9002/7035/7038 both sides.

MATERIAL SPECIFICATION

Material thickness : 1.5mm-2.5mm

Steel Grade : G350-2

Yield Stress : (350MPa - 430MPa)

Coating mass : Z80/Z120/Z180/Z275

TOLERANCES

The following tolerances apply to Z-Purlin and C-Purlin

Depth, D	: ±1mm	Hole centres	: ±1.5mm
Flange Width, F	: ±3mm	Lip, L	: ±3mm
Length	: ±3mm	Thickness, T	: ±8%





APPLICATIONS

INDUSTRIAL SHEDS

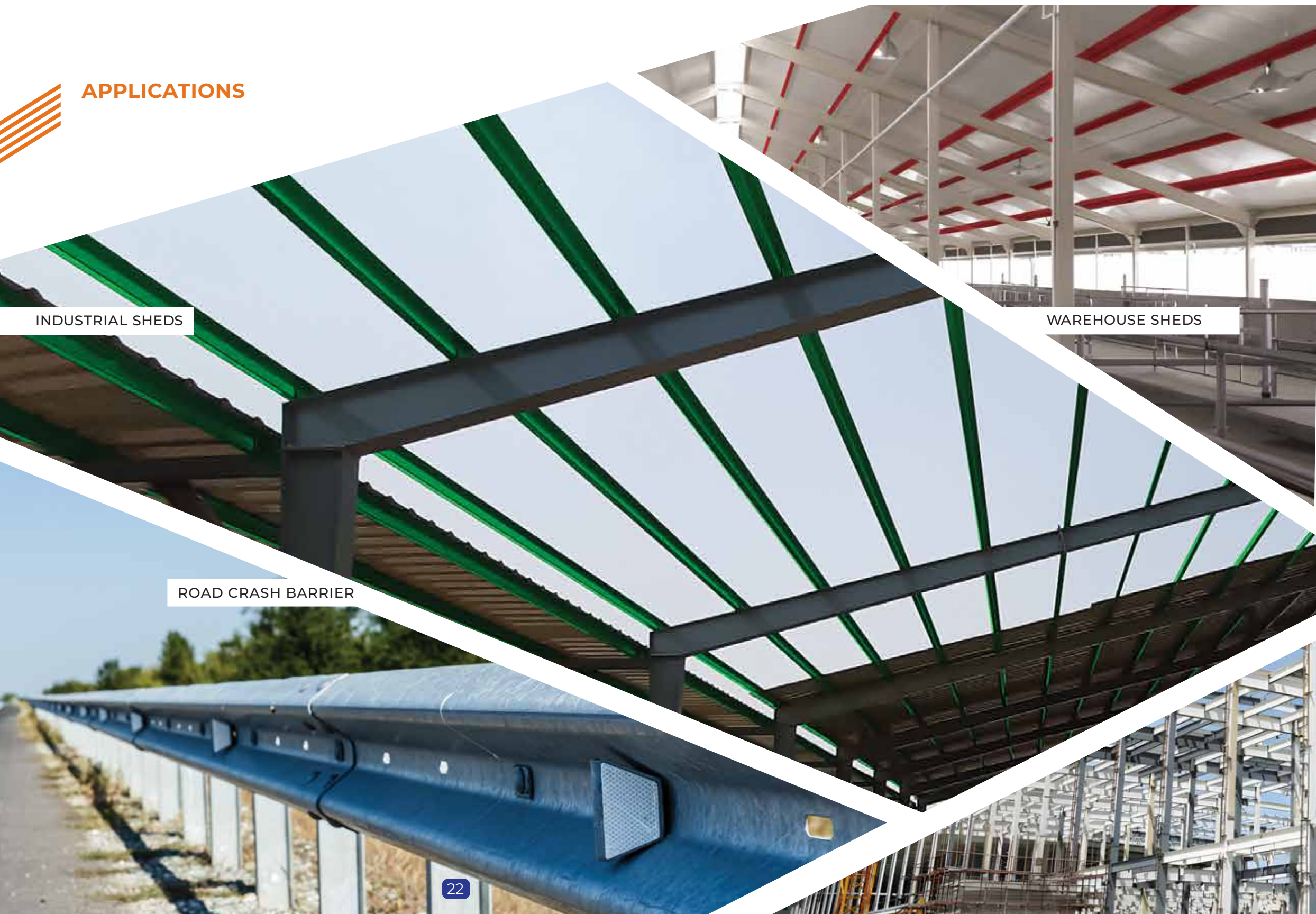

ROAD CRASH BARRIER



WAREHOUSE SHEDS



BUILDING ROOFTOPS



CONSTRUCTION INDUSTRY



ENVIRONMENT

At APL Apollo, we are committed to taking care of the environment by implementing several measures for a better and cleaner tomorrow, while ensuring that the entire process is energy efficient. Our Zero Discharge sustainable policy makes sure that all water used in the production process is treated and reused. This reduces industrial water wastage drastically. We have planted trees in and around our premises and we've converted barren lands into green pastures.



OUR PRESENCE

